

SỐ LIỆU ĐỒ ÁN: SƠ ĐỒ A

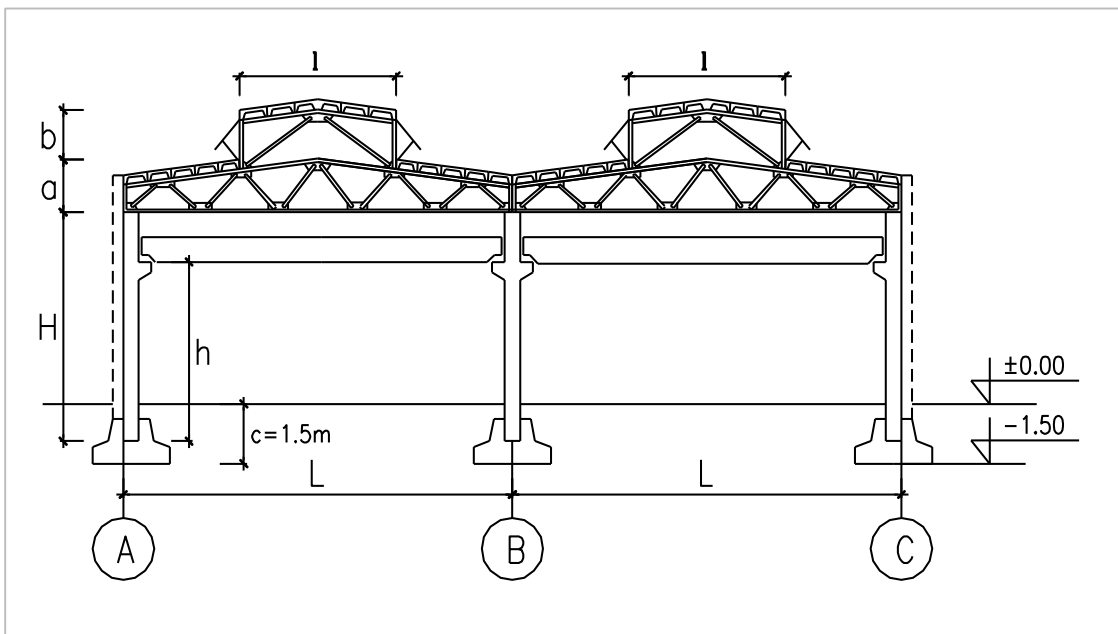

CỘT BÊ TÔNG CỐT THÉP					VÌ KÈO BÊ TÔNG			
TT	H(m)	h(m)	P1(T)	P2(T)	TT	L(m)	a(m)	P(T)
1	7.2	4.8	3.1	3.5	1	18	2.1	3.2
2	7.6	5.2	3.4	3.9	2	24	2.4	4
3	8	5.6	3.7	4.3	3	27	2.7	4.8
4	8.4	6	4	4.7	4	30	3	5.6
5	8.8	6.4	4.3	5.1	5	18	2.3	4.2
6	9.2	6.8	4.6	5.5	6	24	2.6	5
7	9.6	7.2	4.9	5.9	7	27	2.9	5.8
8	10	7.6	5.2	6.3	8	30	3.2	6.6
9	10.4	8	5.5	6.7	9	18	2.4	5.2
10	10.8	8.4	5.8	7.1	10	24	2.7	6
11	11.2	8.8	6.1	7.5	11	27	3	6.8
12	11.6	9.2	6.4	7.9	12	30	3.3	7.6
13	12	9.6	6.7	8.3	13	18	2.5	6.2
14	12.4	10	7	8.7	14	24	2.8	7
15	12.8	10.4	7.3	9.1	15	27	3.1	7.8
16	13.2	10.8	7.6	9.5	16	30	3.4	8.6
17	13.6	11.2	7.9	9.9	17	18	2.7	7.2
18	14	11.6	8.2	10.3	18	24	3	8
19	14.4	12	8.5	10.7	19	27	3.3	8.8
20	14.8	12.4	8.8	11.1	20	30	3.6	9.6

DẪM CẦU CHẠY BT			
TT	Khẩu độ (m)	Cao h(m)	P(T)
1	6	0.8	3.3
2	6	0.9	3.4
3	6	0.8	3.1
4	6	0.7	2.9
5	6	0.8	3
6	6	0.6	2.7
7	6	0.7	3.1
8	6	0.8	3.2
9	6	0.9	3.5
10	6	0.6	2.5
11	6	0.8	3.3
12	6	0.9	3.6
13	6	1	3.7
14	6	1	3.8
15	6	0.9	3.2
16	6	0.8	3.1
17	6	0.9	3.4
18	6	1	3.9
19	6	1	3.5
20	6	0.8	3.6

CỬA TRỜI BÊ TÔNG			
TT	Khẩu độ (m)	Cao b(m)	P(T)
1	6	2.6	1.2
2	9	3	1.8
3	12	3.5	2.1
4	6	2.8	1.5
5	9	3.2	2.1
6	12	3.7	2.4
7	6	3	1.8
8	9	3.4	2.4
9	12	3.9	2.7
10	6	3.2	2.1
11	9	3.6	2.7
12	12	4.1	3
13	6	3.4	2.4
14	9	3.8	3
15	12	4.3	3.3
16	6	3.6	2.7
17	9	4	3.3
18	12	4.5	3.6
19	6	3.8	3
20	12	4.2	3.6

PANEL MÁI & TƯỜNG

TT	Kích thước (m)	P(T)	Kích thước (m)	P(T)
1	1.5x6	1.4	1.5x12	2.8
2	3x6	2.3	3x12	4.6
3	1.5x6	1.5	1.5x12	3
4	3x6	2.4	3x12	4.8
5	1.5x6	1.6	1.5x12	3.2
6	3x6	2.5	3x12	5
7	1.5x6	1.4	1.5x12	2.8
8	3x6	2.3	3x12	4.6
9	1.5x6	1.5	1.5x12	3
10	3x6	2.4	3x12	4.8
11	1.5x6	1.6	1.5x12	3.2
12	3x6	2.5	3x12	5
13	1.5x6	1.4	1.5x12	2.8

14	3x6	2.3	3x12	4.6
15	1.5x6	1.5	1.5x12	3
16	3x6	2.4	3x12	4.8
17	1.5x6	1.6	1.5x12	3.2
18	3x6	2.5	3x12	5
19	1.5x6	1.7	1.5x12	3.4
20	3x6	2.6	3x12	5.2

3x12

SỐ LIỆU ĐỒ ÁN: SƠ ĐỒ B

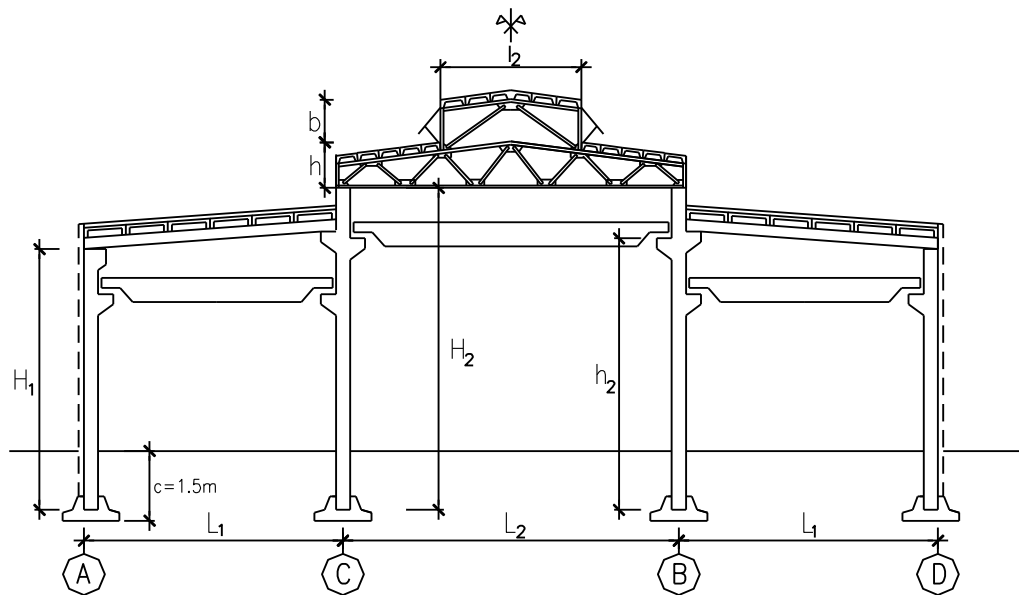

CỘT BÊ TÔNG CỐT THÉP

TT	Cột Ngoài			Cột trong		
	H1(m)	h1(m)	P1(T)	H2(m)	h2(m)	P2(T)
1	7.2	4.8	3.1	9.2	6.8	4.1
2	7.6	5.2	3.4	9.6	7.2	4.4
3	8	5.6	3.7	10	7.6	4.7
4	8.4	6	4	10.4	8	5
5	8.8	6.4	4.3	10.8	8.4	5.3
6	9.2	6.8	4.6	11.2	8.8	5.6
7	9.6	7.2	4.9	11.6	9.2	5.9
8	10	7.6	5.2	12	9.6	6.2
9	10.4	8	5.5	12.4	10	6.5
10	10.8	8.4	5.8	12.8	10.4	6.8
11	11.2	8.8	6.1	13.2	10.8	7.1
12	11.6	9.2	6.4	13.6	11.2	7.4
13	12	9.6	6.7	14	11.6	7.7
14	12.4	10	7	14.4	12	8
15	12.8	10.4	7.3	14.8	12.4	8.3
16	13.2	10.8	7.6	15.2	12.8	8.6
17	13.6	11.2	7.9	15.6	13.2	8.9
18	14	11.6	8.2	16	13.6	9.2
19	14.4	12	8.5	16.4	14	9.5
20	14.8	12.4	8.8	16.8	14.4	9.8

DẪM CẦU CHẠY BT			
TT	Khẩu độ (m)	Cao h(m)	P(T)
1	6	0.8	3.3
2	6	0.9	3.4
3	6	0.8	3.1
4	6	0.7	2.9
5	6	0.8	3
6	6	0.6	2.7
7	6	0.7	3.1
8	6	0.8	3.2
9	6	0.9	3.5
10	6	0.6	2.5
11	6	0.8	3.3
12	6	0.9	3.6
13	6	1	3.7
14	6	1	3.8
15	6	0.9	3.2
16	6	0.8	3.1
17	6	0.9	3.4
18	6	1	3.9
19	6	1	3.5
20	6	0.8	3.6

DẪM MÁI BÊ TÔNG			
TT	L1 (m)	Cao h(m)	P(T)
1	6	0.5	3.3
2	9	0.6	4.1
3	12	0.8	4.5
4	15	1	6.2
5	18	1.2	8.8
6	6	0.6	3.5
7	9	0.7	4.3
8	12	0.9	4.7
9	15	1.1	6.4
10	18	1.3	9
11	6	0.7	3.7
12	9	0.8	4.5
13	12	1	4.9
14	15	1.2	6.6
15	18	1.4	9.2
16	6	0.8	3.9
17	9	0.9	4.7
18	12	1.1	5.1
19	15	1.3	6.8
20	18	1.5	9.4

VÌ KÈO THÉP			
TT	L2(m)	H(m)	P(T)
1	18	2.1	1.5
2	24	2.4	2.7
3	27	2.7	3.2
4	30	3	4
5	18	2.3	1.8
6	24	2.6	3
7	27	2.9	3.5
8	30	3.2	4.3
9	18	2.4	2.1
10	24	2.7	3.3
11	27	3	3.8
12	30	3.3	4.6

CỬA TRỜI BẰNG THÉP			
TT	Khẩu độ (m)	Cao b(m)	P(T)
1	6	2.6	0.5
2	9	3	0.7
3	12	3.5	0.9
4	6	2.8	0.8
5	9	3.2	1
6	12	3.7	1.2
7	6	3	1.1
8	9	3.4	1.3
9	12	3.9	1.5
10	6	3.2	1.4
11	9	3.6	1.6
12	12	4.1	1.8

13	18	2.5	2.4
14	24	2.8	3.6
15	27	3.1	4.1
16	30	3.4	4.9
17	18	2.7	2.7
18	24	3	3.9
19	27	3.3	4.4
20	30	3.6	5.2

13	6	3.4	1.7
14	9	3.8	1.9
15	12	4.3	2.1
16	6	3.6	2
17	9	4	2.2
18	12	4.5	2.4
19	6	3.8	2.3
20	12	4.2	2.5

PANEL MÁI & TƯỜNG

TT	Kích thước (m)	P(T)	Kích thước (m)	P(T)
1	1.5x6	1.4	1.5x12	2.8
2	3x6	2.3	3x12	4.6
3	1.5x6	1.5	1.5x12	3
4	3x6	2.4	3x12	4.8
5	1.5x6	1.6	1.5x12	3.2
6	3x6	2.5	3x12	5
7	1.5x6	1.4	1.5x12	2.8
8	3x6	2.3	3x12	4.6
9	1.5x6	1.5	1.5x12	3
10	3x6	2.4	3x12	4.8
11	1.5x6	1.6	1.5x12	3.2
12	3x6	2.5	3x12	5
13	1.5x6	1.4	1.5x12	2.8
14	3x6	2.3	3x12	4.6
15	1.5x6	1.5	1.5x12	3
16	3x6	2.4	3x12	4.8
17	1.5x6	1.6	1.5x12	3.2
18	3x6	2.5	3x12	5
19	1.5x6	1.7	1.5x12	3.4
20	3x6	2.6	3x12	5.2

SỐ LIỆU ĐỒ ÁN: SƠ ĐỒ C

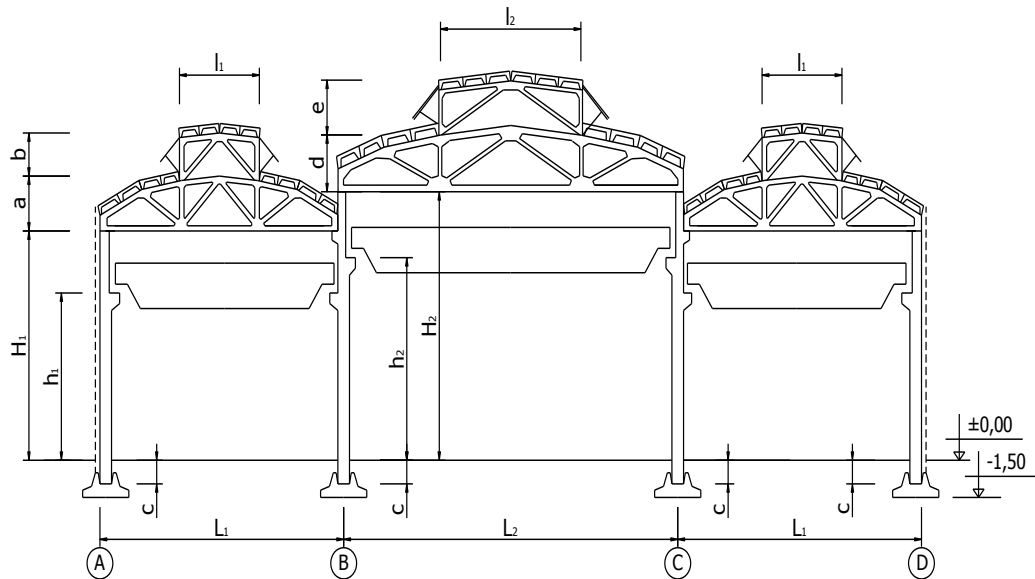

CỘT BÊ TÔNG CỐT THÉP						
Cột Ngoài				Cột trong		
TT	H1(m)	h1(m)	P1(T)	H2(m)	h2(m)	P2(T)
1	7.2	4.8	3.1	9.2	6.8	4.1
2	7.6	5.2	3.4	9.6	7.2	4.4
3	8	5.6	3.7	10	7.6	4.7
4	8.4	6	4	10.4	8	5
5	8.8	6.4	4.3	10.8	8.4	5.3
6	9.2	6.8	4.6	11.2	8.8	5.6
7	9.6	7.2	4.9	11.6	9.2	5.9
8	10	7.6	5.2	12	9.6	6.2
9	10.4	8	5.5	12.4	10	6.5
10	10.8	8.4	5.8	12.8	10.4	6.8
11	11.2	8.8	6.1	13.2	10.8	7.1
12	11.6	9.2	6.4	13.6	11.2	7.4
13	12	9.6	6.7	14	11.6	7.7
14	12.4	10	7	14.4	12	8
15	12.8	10.4	7.3	14.8	12.4	8.3
16	13.2	10.8	7.6	15.2	12.8	8.6
17	13.6	11.2	7.9	15.6	13.2	8.9
18	14	11.6	8.2	16	13.6	9.2
19	14.4	12	8.5	16.4	14	9.5
20	14.8	12.4	8.8	16.8	14.4	9.8

VỊ KÈO BÊ TÔNG 1				VỊ KÈO BÊ TÔNG 2		
TT	L1(m)	a(m)	P(T)	L2(m)	d(m)	P(T)
1	15	2.1	1.5	30	2.2	2.9
2	18	2.4	2.7	27	2.4	3.2
3	24	2.7	3.2	24	2.6	3.1
4	30	3	4	15	2.7	1.9
5	15	2.3	1.8	30	2.3	3.1
6	18	2.6	3	27	2.5	3.4
7	24	2.9	3.5	24	2.7	3.3
8	30	3.2	4.3	15	2.8	2.1
9	15	2.4	2.1	30	2.4	3.3
10	18	2.7	3.3	27	2.6	3.6
11	24	3	3.8	24	2.8	3.5
12	30	3.3	4.6	15	2.9	2.3
13	15	2.5	2.4	30	2.5	3.5
14	18	2.8	3.6	27	2.7	3.8
15	24	3.1	4.1	24	2.9	3.7
16	30	3.4	4.9	15	3	2.5
17	15	2.7	2.7	30	2.6	3.7
18	18	3	3.9	27	2.8	4
19	24	3.3	4.4	24	3	3.9
20	30	3.6	5.2	15	3.1	2.7

DÀM CẦU CHẠY BT			
TT	Khẩu độ (m)	Cao h(m)	P(T)
1	6	0.8	3.3
2	6	0.9	3.4
3	6	0.8	3.1
4	6	0.7	2.9
5	6	0.8	3
6	6	0.6	2.7
7	6	0.7	3.1
8	6	0.8	3.2
9	6	0.9	3.5
10	6	0.6	2.5
11	6	0.8	3.3
12	6	0.9	3.6

CỬA TRỜI BÊ TÔNG			
TT	l1 = l2 (m)	b,e(m)	P(T)
1	6	2.6	1.2
2	9	3	1.8
3	12	3.5	2.1
4	6	2.8	1.5
5	9	3.2	2.1
6	12	3.7	2.4
7	6	3	1.8
8	9	3.4	2.4
9	12	3.9	2.7
10	6	3.2	2.1
11	9	3.6	2.7
12	12	4.1	3

13	6	1	3.7
14	6	1	3.8
15	6	0.9	3.2
16	6	0.8	3.1
17	6	0.9	3.4
18	6	1	3.9
19	6	1	3.5
20	6	0.8	3.6

13	6	3.4	2.4
14	9	3.8	3
15	12	4.3	3.3
16	6	3.6	2.7
17	9	4	3.3
18	12	4.5	3.6
19	6	3.8	3
20	12	4.2	3.6

PANEL MÁI & TƯỜNG

TT	Kích thước (m)	P(T)	Kích thước (m)	P(T)
1	1.5x6	1.4	1.5x12	2.8
2	3x6	2.3	3x12	4.6
3	1.5x6	1.5	1.5x12	3
4	3x6	2.4	3x12	4.8
5	1.5x6	1.6	1.5x12	3.2
6	3x6	2.5	3x12	5
7	1.5x6	1.4	1.5x12	2.8
8	3x6	2.3	3x12	4.6
9	1.5x6	1.5	1.5x12	3
10	3x6	2.4	3x12	4.8
11	1.5x6	1.6	1.5x12	3.2
12	3x6	2.5	3x12	5
13	1.5x6	1.4	1.5x12	2.8
14	3x6	2.3	3x12	4.6
15	1.5x6	1.5	1.5x12	3
16	3x6	2.4	3x12	4.8
17	1.5x6	1.6	1.5x12	3.2
18	3x6	2.5	3x12	5
19	1.5x6	1.7	1.5x12	3.4
20	3x6	2.6	3x12	5.2

SỐ LIỆU ĐỒ ÁN: SƠ ĐỒ D

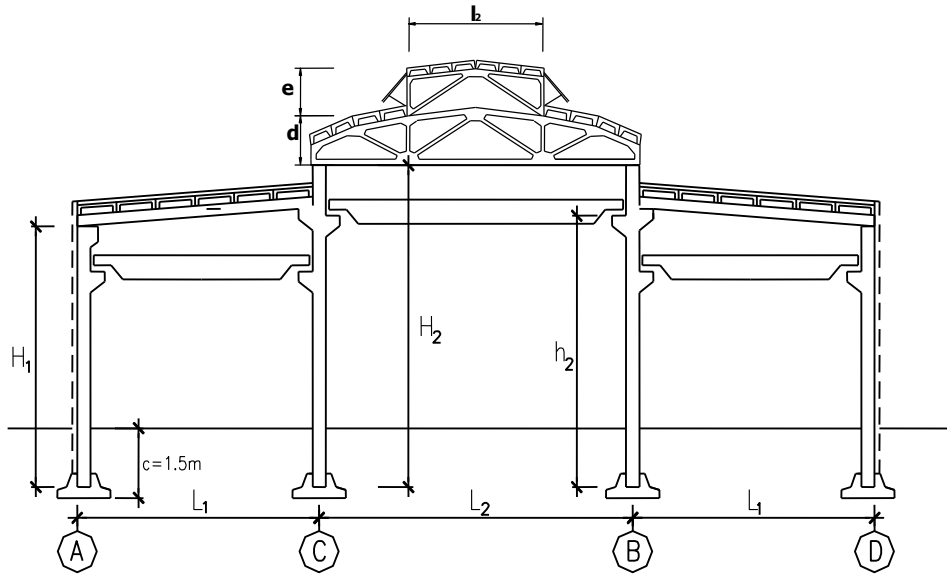

CỘT BÊ TÔNG CỐT THÉP						
Cột Ngoài				Cột trong		
TT	H1(m)	h1(m)	P1(T)	H2(m)	h2(m)	P2(T)
1	7.2	4.8	3.1	9.2	6.8	4.1
2	7.6	5.2	3.4	9.6	7.2	4.4
3	8	5.6	3.7	10	7.6	4.7
4	8.4	6	4	10.4	8	5
5	8.8	6.4	4.3	10.8	8.4	5.3
6	9.2	6.8	4.6	11.2	8.8	5.6
7	9.6	7.2	4.9	11.6	9.2	5.9
8	10	7.6	5.2	12	9.6	6.2
9	10.4	8	5.5	12.4	10	6.5
10	10.8	8.4	5.8	12.8	10.4	6.8
11	11.2	8.8	6.1	13.2	10.8	7.1
12	11.6	9.2	6.4	13.6	11.2	7.4
13	12	9.6	6.7	14	11.6	7.7
14	12.4	10	7	14.4	12	8
15	12.8	10.4	7.3	14.8	12.4	8.3
16	13.2	10.8	7.6	15.2	12.8	8.6
17	13.6	11.2	7.9	15.6	13.2	8.9
18	14	11.6	8.2	16	13.6	9.2
19	14.4	12	8.5	16.4	14	9.5
20	14.8	12.4	8.8	16.8	14.4	9.8

DẪM CẦU CHẠY BT			
TT	Khẩu độ (m)	Cao h(m)	P(T)
1	6	0.8	3.3
2	6	0.9	3.4
3	6	0.8	3.1
4	6	0.7	2.9
5	6	0.8	3
6	6	0.6	2.7
7	6	0.7	3.1
8	6	0.8	3.2
9	6	0.9	3.5
10	6	0.6	2.5
11	6	0.8	3.3
12	6	0.9	3.6
13	6	1	3.7
14	6	1	3.8
15	6	0.9	3.2
16	6	0.8	3.1
17	6	0.9	3.4
18	6	1	3.9
19	6	1	3.5
20	6	0.8	3.6

DẪM MÁI BÊ TÔNG			
TT	L1 (m)	Cao h(m)	P(T)
1	6	0.8	3.3
2	9	0.9	4
3	12	1	5.1
4	15	1.1	6
5	18	1.2	8.8
6	6	0.9	3.5
7	9	1	4.2
8	12	1.1	5.3
9	15	1.2	6.2
10	18	1.3	9
11	6	1	3.7
12	9	1.1	4.4
13	12	1.2	5.5
14	15	1.3	6.4
15	18	1.4	9.2
16	6	1.1	3.9
17	9	1.2	4.6
18	12	1.3	5.7
19	15	1.4	6.6
20	18	1.5	9.4

VÌ KÈO BÊ TÔNG			
TT	Khẩu độ L2(m)	d(m)	P(T)
1	18	2.1	3.2
2	24	2.4	4
3	27	2.7	4.8
4	30	3	5.6
5	18	2.3	4.2
6	24	2.6	5
7	27	2.9	5.8
8	30	3.2	6.6
9	18	2.4	5.2
10	24	2.7	6
11	27	3	6.8
12	30	3.3	7.6
13	18	2.5	6.2

CỬA TRỜI BÊ TÔNG			
TT	Khẩu độ l2 (m)	Cao e (m)	P(T)
1	6	2.6	1.2
2	9	3	1.8
3	12	3.5	2.1
4	6	2.8	1.5
5	9	3.2	2.1
6	12	3.7	2.4
7	6	3	1.8
8	9	3.4	2.4
9	12	3.9	2.7
10	6	3.2	2.1
11	9	3.6	2.7
12	12	4.1	3
13	6	3.4	2.4

14	24	2.8	7
15	27	3.1	7.8
16	30	3.4	8.6
17	18	2.7	7.2
18	24	3	8
19	27	3.3	8.8
20	30	3.6	9.6

14	9	3.8	3
15	12	4.3	3.3
16	6	3.6	2.7
17	9	4	3.3
18	12	4.5	3.6
19	6	3.8	3
20	12	4.2	3.6