

# LIEBHERR 32 TT

## SELF-ERECTING CRANE

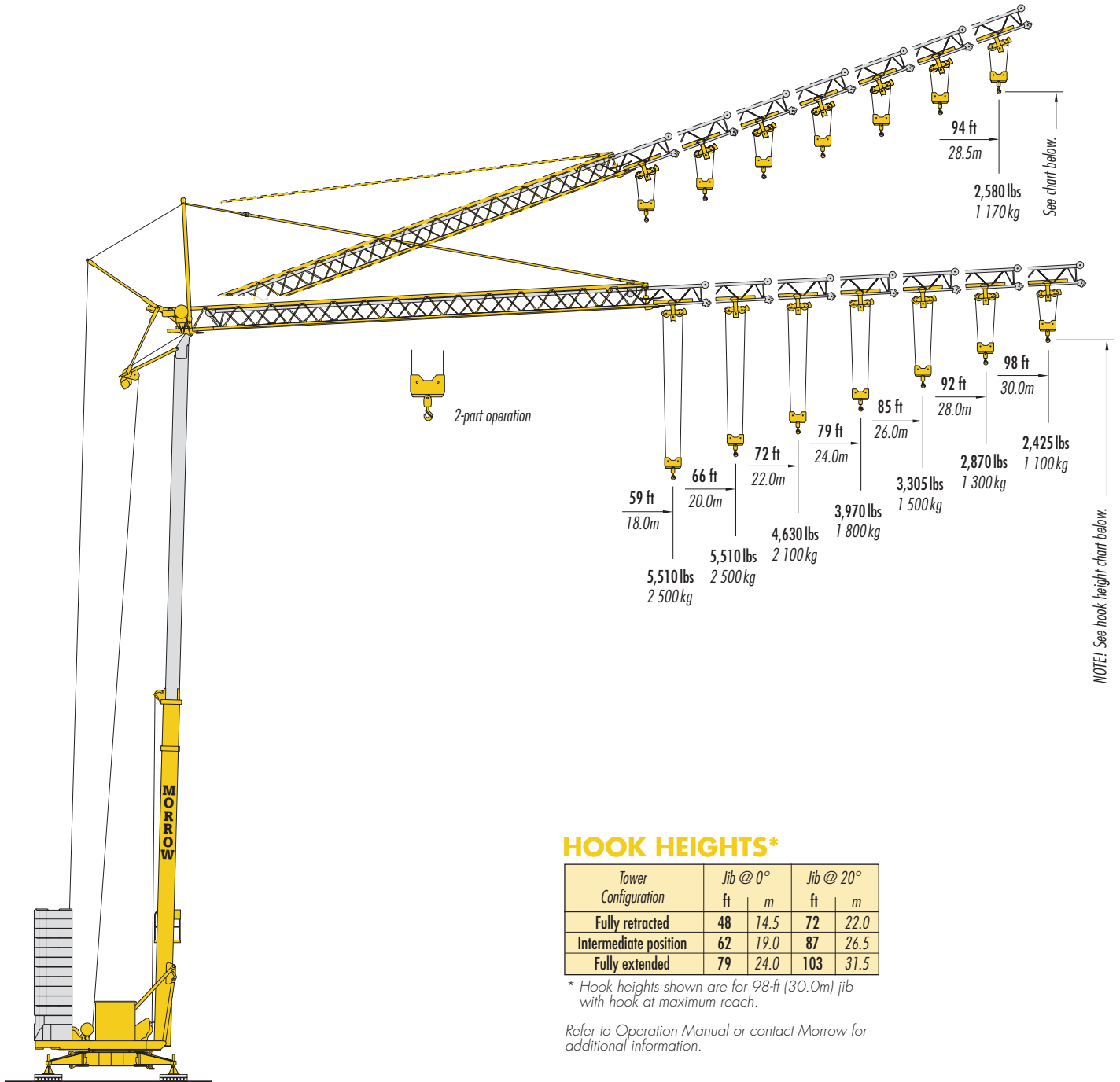

### HOOK HEIGHTS\*

Tower Configuration	Jib @ 0°		Jib @ 20°	
	ft	m	ft	m
Fully retracted	48	14.5	72	22.0
Intermediate position	62	19.0	87	26.5
Fully extended	79	24.0	103	31.5

\* Hook heights shown are for 98-ft (30.0m) jib with hook at maximum reach.

Refer to Operation Manual or contact Morrow for additional information.

### STATIONARY

on outriggers with spindle jacks  
maximum height under hook  
103 ft (31.5m)



# Morrow Equipment

# LIEBHERR 32 TT

\* NOTE! 2/4-part operation available only with jib at 0°.

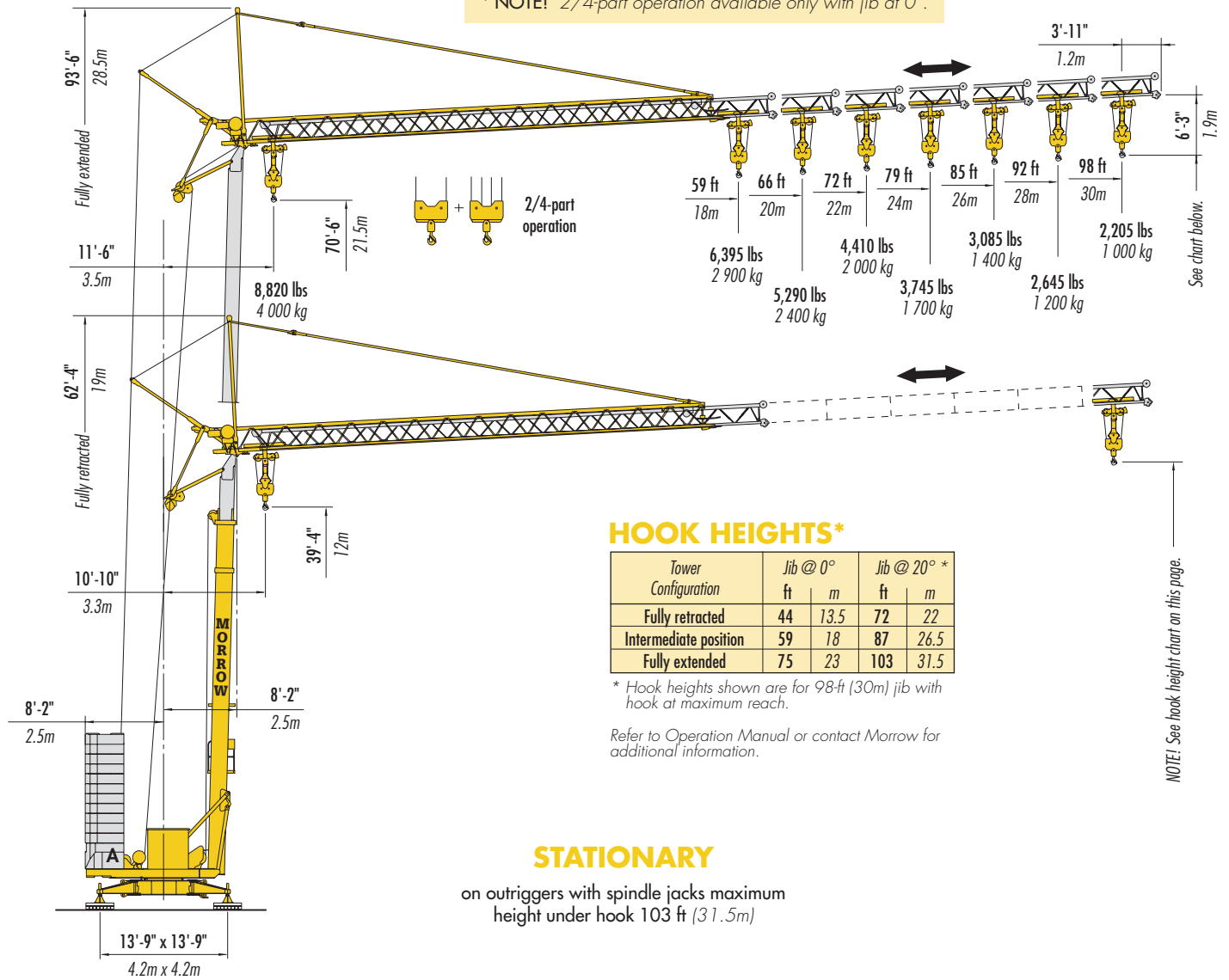

## Weight Information

Component	Weight**
Crane (with "A" ballast block; without coupler, extension and axle)	34,750 lbs / 15,760 kg
Rear axle assembly (dual axle TRA-203)	5,300 lbs / 2,400 kg
5th wheel coupler	1,850 lbs / 840 kg
Coupler extension	900 lbs / 410 kg
A-type ballast block (1 required)	6,620 lbs / 3,000 kg
B-type ballast block (each) (10 or 11 required; see Operation Manual)	3,860 lbs / 1,750 kg
Crane with axle and coupler assemblies (complete road-ready transport unit)	42,800 lbs / 19,420 kg

\*\* Weights are approximate. Verify weights before transporting, assembling or erecting crane. Refer to 32TT Operation Manual for more information.

# LIEBHERR 32 TT

**IMPORTANT!** Please consult crane's operation manual before erecting, operating and dismantling crane.

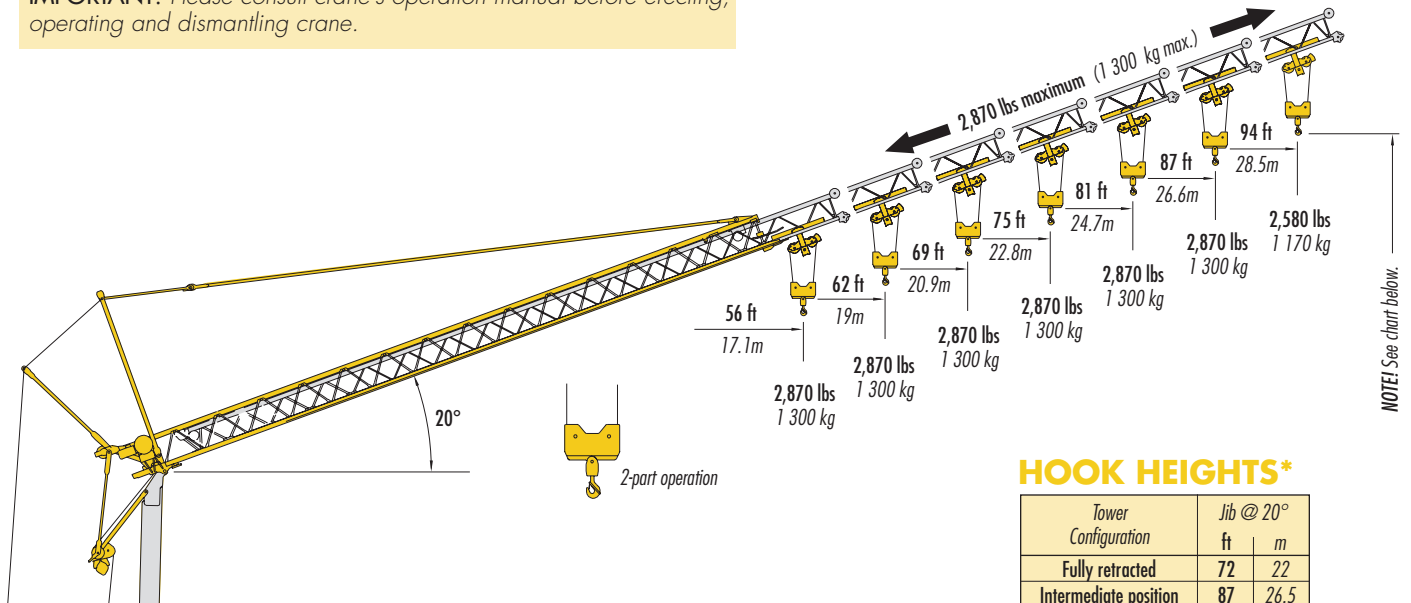

## HOOK HEIGHTS\*

Tower Configuration	Jib @ 20°	
	ft	m
Fully retracted	72	22
Intermediate position	87	26.5
Fully extended	103	31.5

\* Hook heights shown are for 98-ft (30m) jib with hook at maximum reach.

Refer to Operation Manual or contact Morrow for additional information.

## Jib in Luffed Position

in 2-part operation at 20°

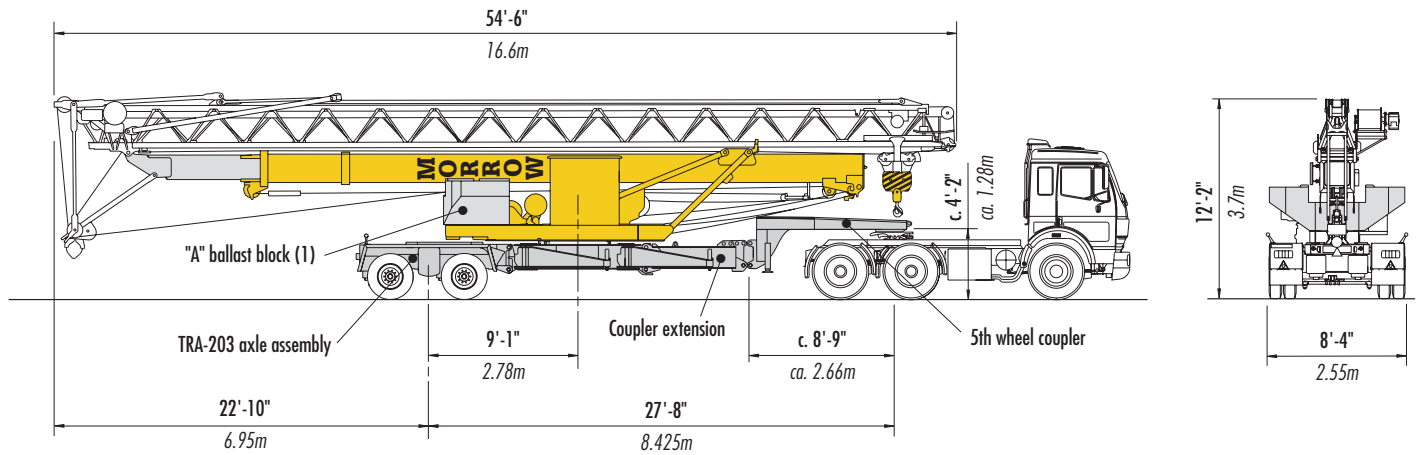









## TRANSPORTER









fifth-wheel towing unit with A-type ballast block installed  
(weight approximately 42,800 lbs/19,420 kg)

## Radius & Capacities

### 2-Part Line

Hook reach	Maximum capacity		ft m	11	33	53	56	59	63	66	69	72	75	79	82	85	89	92	95	98
				3.3	10	16	17	18	19	20	21	22	23	24	25	26	27	28	29	30
98 ft 30m	5,510 lbs – 53.5 ft 2 500 kg – 16.3m		lbs kg	5,510 2 500	5,510 2 500	5,510 2 500	5,203 2 360	4,806 2 180	4,475 2 030	4,189 1 900	3,924 1 780	3,682 1 670	3,461 1 570	3,285 1 490	3,109 1 410	2,954 1 340	2,800 1 270	2,668 1 210	2,535 1 150	2,425 1 100
92 ft 28m	5,510 lbs – 56.1 ft 2 500 kg – 17.1m		lbs kg	5,510 2 500	5,510 2 500	5,510 2 500	5,510 2 500	5,159 2 340	4,806 2 180	4,475 2 030	4,189 1 900	3,946 1 790	3,726 1 690	3,527 1 600	3,329 1 510	3,175 1 440	3,020 1 370	2,870 1 300		
85 ft 26m	5,510 lbs – 58.1 ft 2 500 kg – 17.7m		lbs kg	5,510 2 500	5,510 2 500	5,510 2 500	5,510 2 500	5,379 2 440	5,004 2 270	4,674 2 120	4,387 1 990	4,123 1 870	3,880 1 760	3,682 1 670	3,483 1 580	3,305 1 500				
79 ft 24m	5,510 lbs – 61.4 ft 2 500 kg – 18.7m		lbs kg	5,510 2 500	5,510 2 500	5,510 2 500	5,510 2 500	5,379 2 440	5,027 2 280	4,718 2 140	4,453 2 020	4,189 1 900	3,970 1 800							
72 ft 22m	5,510 lbs – 63 ft 2 500 kg – 19.2m		lbs kg	5,510 2 500	5,510 2 500	5,510 2 500	5,510 2 500	5,510 2 500	5,510 2 500	5,247 2 380	4,916 2 230	4,630 2 100								
66 ft 20m	5,510 lbs – 66 ft 2 500 kg – 20.0m		lbs kg	5,510 2 500	5,510 2 500	5,510 2 500	5,510 2 500	5,510 2 500	5,510 2 500	5,510 2 500										
59 ft 18m	5,510 lbs – 59 ft 2 500 kg – 18m		lbs kg	5,510 2 500	5,510 2 500	5,510 2 500	5,510 2 500	5,510 2 500												

### 2/4-Part Line

Hook reach	Maximum capacity		ft m	11	33	53	56	59	63	66	69	72	75	79	82	85	89	92	95	98
				3.3	10	16	17	18	19	20	21	22	23	24	25	26	27	28	29	30
98 ft 30m	8,820 lbs – 36.7 ft 4 000 kg – 11.2m		lbs kg	8,820 4 000	8,820 4 000	5,360 2 430	4,938 2 240	4,564 2 070	4,233 1 920	3,924 1 780	3,682 1 670	3,439 1 560	3,241 1 470	3,042 1 380	2,866 1 300	2,712 1 230	2,579 1 170	2,447 1 110	2,315 1 050	2,205 1 000
92 ft 28m	8,820 lbs – 38.7 ft 4 000 kg – 11.8m		lbs kg	8,820 4 000	8,820 4 000	5,750 2 610	5,291 2 400	4,894 2 220	4,542 2 060	4,233 1 920	3,968 1 800	3,704 1 680	3,483 1 580	3,285 1 490	3,109 1 410	2,932 1 330	2,778 1 260	2,645 1 200		
85 ft 26m	8,820 lbs – 39.7 ft 4 000 kg – 12.1m		lbs kg	8,820 4 000	8,820 4 000	6,000 2 720	5,534 2 510	5,115 2 320	4,762 2 160	4,431 2 010	4,145 1 880	3,880 1 760	3,660 1 660	3,461 1 570	3,263 1 480	3,085 1 400				
79 ft 24m	8,820 lbs – 42 ft 4 000 kg – 12.8m		lbs kg	8,820 4 000	8,820 4 000	6,480 2 940	5,975 2 710	5,534 2 510	5,137 2 330	4,806 2 180	4,497 2 040	4,211 1 910	3,968 1 800	3,745 1 700						
72 ft 22m	8,820 lbs – 43.3 ft 4 000 kg – 13.2m		lbs kg	8,820 4 000	8,820 4 000	6,770 3 070	6,239 2 830	5,776 2 620	5,379 2 440	5,004 2 270	4,696 2 130	4,410 2 000								
66 ft 20m	8,820 lbs – 44.9 ft 4 000 kg – 13.7m		lbs kg	8,820 4 000	8,820 4 000	7,120 3 230	6,570 2 980	6,085 2 760	5,666 2 570	5,290 2 400										
59 ft 18m	8,820 lbs – 46.6 ft 4 000 kg – 14.2m		lbs kg	8,820 4 000	8,820 4 000	7,470 3 390	6,900 3 130	6,395 2 900												

NOTE! 2/4-part operation available only with jib at 0°.

# LIEBHERR 32 TT

## Erection Sequence

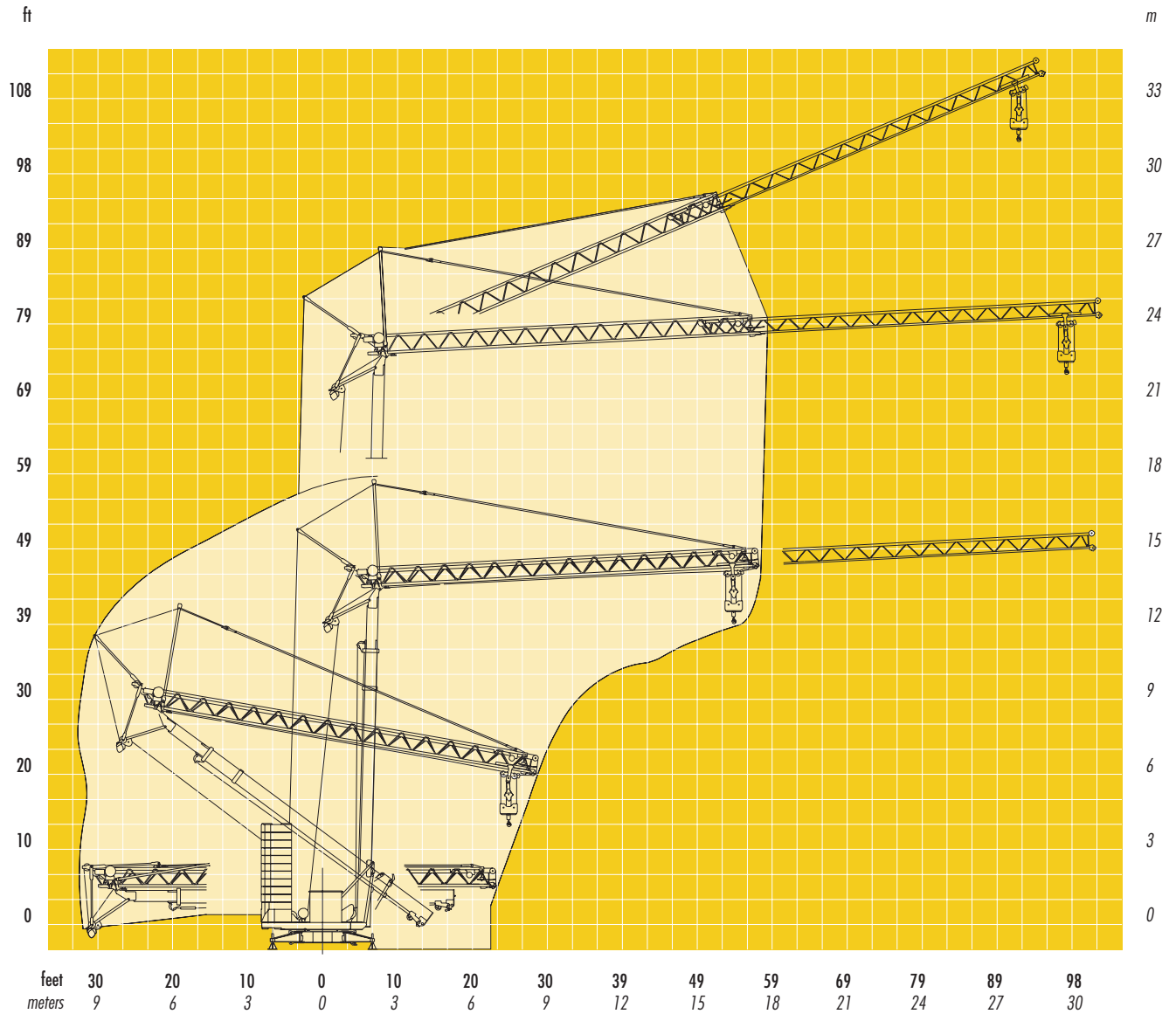

## Drive Information

### Hoist Speed and Capacity

Hoist Unit	2-Part Line					
	Step	Capacity	Line Speed	Capacity	Line Speed	
14.7 hp (11 kW) AC hoist unit  • 4-step motor with frequency converter speed control	1	up to 5,510 lbs	@ 13 fpm	up to 2 500 kg	@ 4 m/min	
	2	up to 5,510 lbs	@ 66 fpm	up to 2 500 kg	@ 20 m/min	
	3	up to 2,870 lbs	@ 125 fpm	up to 1 300 kg	@ 38 m/min	
	4	up to 2,205 lbs	@ 164 fpm	up to 1 000 kg	@ 50 m/min	
	4-Part Line					
	1	up to 8,820 lbs	@ 6.5 fpm	up to 4 000 kg	@ 2 m/min	
	2	up to 8,820 lbs	@ 33 fpm	up to 4 000 kg	@ 10 m/min	
	3	up to 5,735 lbs	@ 62.5 fpm	up to 2 600 kg	@ 19 m/min	
4	up to 4,410 lbs	@ 82 fpm	up to 2 000 kg	@ 25 m/min		

**NOTE!** Capacities and line speeds indicated in the charts above will vary depending on the amount of hoist rope installed. This crane model may be equipped with a hoist unit other than those specified in the data above. To verify, check the serial number of the crane and refer to the Liebherr 32 TT Operation Manual for additional information.

### Motor Information

Drive Unit	Horsepower	Kilowatts	Speed	
Trolley (KAW130KV007)	2.4/4.7 hp	1.8/3.5 kW	82/164 fpm	25/50 m/min
Trolley (KAW140KV032)	3.5/4.7 hp	2.8/3.5 kW	82/164 fpm	25/50 m/min
Swing	3 hp	2.2 kW	0.8 rpm	

### Power Requirements

480 V — 3-phase — 60 Hz — 30 Amperes

Subject to changes without prior notice. For additional information, contact Morrow Equipment.



**Morrow Equipment**  
C O M P A N Y, L. L. C.

3218 Pringle Road SE • P O Box 3306 • Salem, Oregon 97302-0306 USA  
503.585.5721 • Fax. 503.363.1172 • www.morrow.com • info@morrow.com

The American home of  
**LIEBHERR**  
TOWER CRANES

Atlanta, GA • Charlotte, NC • Chicago, IL • Denver, CO • Honolulu, HI • Houston, TX • Los Angeles, CA • Las Vegas, NV  
Millwood, NY • St. Louis, MO • San Francisco, CA • Dallas, TX • Seattle, WA • Miami, FL • Tampa, FL • Washington, DC  
Sydney, Australia • Wellington, New Zealand • Vancouver, BC, Canada • Toronto, ON, Canada • México DF, México